

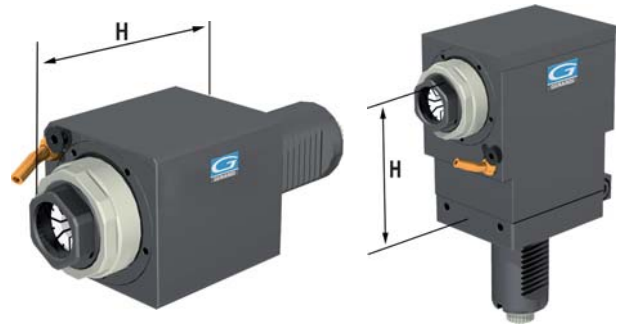

Motorized toolholder with DIN 5480 VDI seat

Motorized toolholder compatible for all lathes with turrets with VDI seat. Rotation direction against the spindle.



Code	€	Connection type	For pliers (ER)	Type	Coolant passage	H (mm)	Torque (Nm)	Max speed (rev/min)
C456100005	---	VDI30	25	axial	no	66	32	6000
C456100010	---	VDI30	25	axial	yes	66	32	6000
C456100025	---	VDI40	32	axial	no	95	63	6000
C456100030	---	VDI40	32	axial	yes	95	63	6000
C456100015	---	VDI30	25	radial	no	55	32	6000
C456100020	---	VDI30	25	radial	yes	55	32	6000
C456100035	---	VDI40	32	radial	no	100	63	6000
C456100040	---	VDI40	32	radial	yes	100	63	6000



Motorized toolholder for DMG Mori lathe

Motorized toolholder for lathe DMG Mori NLX 1500 - 2000 - 2500 - 3000 16 stations, NZX 12 stations. Rotation direction equal to the spindle.

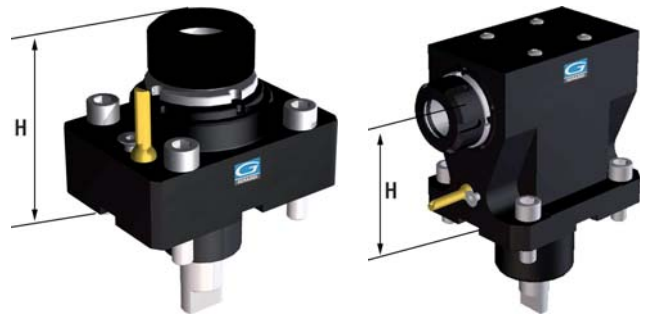

Code	€	For pliers (ER)	Type	Coolant passage	H (mm)	Torque (Nm)	Max speed (rev/min)
C456150005	---	32	axial	no	86,2÷89,9	60	10000
C456150010	---	32	axial	yes	86,2÷89,9	60	10000
C456150015	---	40	axial	no	86,2÷89,9	60	10000
C456150020	---	40	axial	yes	88,3÷92	60	10000
C456150025	---	32	radial	no	Max 90	60	10000
C456150030	---	32	radial	yes	Max 90	60	10000
C456150035	---	40	radial	no	90	60	10000
C456150040	---	40	radial	yes	90	60	10000



Motorized toolholder for Mazak QTN2 lathe

Motorized toolholder for Mazak QTN2 lathe type: QUICK TURN NEXUS QTN 200/250 SUPER QUADREX TURN SQT 15/18 - 200/250. Rotation direction against the spindle.



Code	€	For pliers (ER)	Type	Coolant passage	H (mm)	Torque (Nm)	Max speed (rev/min)
C456200005	---	32	axial	no	116,2÷120	80	6000
C456200010	---	32	axial	yes	116,2÷120	80	6000
C456200015	---	32	radial	no	130	80	6000
C456200020	---	32	radial	yes	130	80	6000