



Clamping equipment with vertical lever

Clamping equipment with vertical lever, heavy clamping arm, horizontal assembly base.

Features: galvanized and passivated tools, with stainless steel rivets, PVC handgrip, oil resistant.

Use: in all cases requiring holding forces up to 3600 N for assembly, drilling, testing, glueing and welding masks.

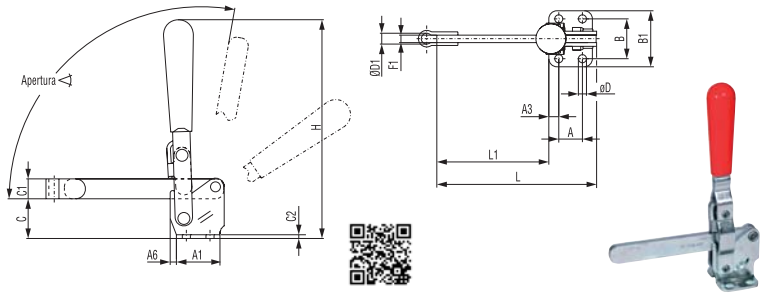

| Code | € | Retaining force (N) | Opening (°) | Weight (Kg) | A (mm) | A1 (mm) | A3 (mm) | A6 (mm) | B (mm) | B1 (mm) | C (mm) | C1 (mm) | C2 (mm) | øD (mm) | øD1 (mm) | F1 (mm) | H (mm) | L (mm) | L1 (mm) | |
|------------|-----|---------------------|-------------|-------------|--------|---------|---------|---------|--------|---------|--------|---------|---------|---------|----------|---------|--------|--------|---------|-------|
| C603170005 | --- | 2200 | 100 | 0,38 | 19,1 | 35,1 | 7,9 | 3,8 | 31,8 | 43,9 | 32 | 16 | 3 | 7,1 | 7,1 | 8,6 | 6,4 | 176 | 128,5 | 88,4 |
| C603170010 | --- | 3400 | 105 | 0,6 | 32 | 48 | 7,9 | 10,7 | 45 | 65 | 42,4 | 20,1 | 3 | 8,4 | 8,4 | 13 | 7,9 | 208 | 138,9 | 90,9 |
| C603170015 | --- | 4500 | 120 | 1,1 | 32 | 50,8 | 9,4 | 11,9 | 45,2 | 64 | 50,3 | 22,1 | 4,8 | 8,9 | 8,9 | 14,5 | 9,7 | 225 | 178,3 | 124,2 |
| C603170020 | --- | 5400 | 140 | 2,2 | 50,8 | 76,2 | 12,7 | - | 70,1 | 95,3 | 78,2 | 31,8 | 4,8 | 12,2 | 12,2 | 16,3 | 9,7 | 303,3 | 225,6 | 149,4 |



Clamping equipment with vertical lever

Clamping equipment with vertical lever, heavy clamping arm, vertical assembly base.

Features: galvanized and passivated tools, with stainless steel rivets, PVC handgrip, oil resistant.

Use: in all cases requiring holding forces up to 4500 N for assembly, drilling, testing, glueing and welding masks.

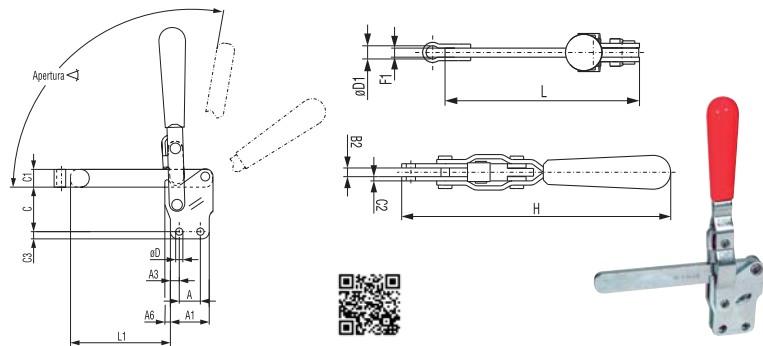

| Code | € | Retaining force (N) | Opening (°) | Weight (Kg) | A (mm) | A1 (mm) | A3 (mm) | A6 (mm) | B2 (mm) | C (mm) | C1 (mm) | C2 (mm) | C3 (mm) | øD (mm) | øD1 (mm) | F1 (mm) | H (mm) | L (mm) | L1 (mm) |
|------------|-----|---------------------|-------------|-------------|--------|---------|---------|---------|---------|--------|---------|---------|---------|---------|----------|---------|--------|--------|---------|
| C603220005 | --- | 2200 | 100 | 0,38 | 19,1 | 35,1 | 7,9 | 3,8 | 6 | 40 | 16 | 3 | 6,3 | 7,1 | 8,6 | 6,4 | 189,7 | 128,5 | 88,4 |
| C603220010 | --- | 3400 | 105 | 0,6 | 32 | 48 | 7,9 | 10,7 | 7,9 | 55,9 | 20,1 | 3 | 9,9 | 8,4 | 13 | 7,9 | 231,4 | 140 | 91,9 |
| C603220015 | --- | 4500 | 120 | 1,1 | 32 | 51 | 9,5 | 12 | 9,5 | 57 | 22 | 4,5 | 9,5 | 8,5 | 14 | 9,5 | 239,5 | 178 | 124 |



Clamping equipment with horizontal lever

Horizontal clamping equipment, with U-shaped clamping arm, with pressure screw included, horizontal assembly base.

Features: galvanized and passivated tools, with stainless steel rivets, PVC handgrip, oil resistant.

Use: in all fields requiring holding forces up to 3200 N for assembly, drilling, testing, glueing and welding masks.

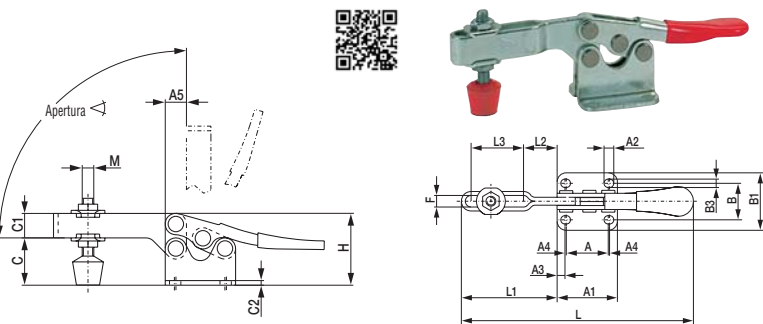

| Code | € | Retaining force (N) | Opening (°) | Weight (Kg) | Pressure screw (MxL) | A (mm) | A1 (mm) | A2 (mm) | A3 (mm) | A4 (mm) | A5 (mm) | B (mm) | B1 (mm) | B3 (mm) | C (mm) | C1 (mm) | C2 (mm) | F (mm) | H (mm) | L (mm) | L1 (mm) | L2 (mm) | L3 (mm) |
|------------|-----|---------------------|-------------|-------------|----------------------|--------|---------|---------|---------|---------|---------|--------|---------|---------|--------|---------|---------|--------|--------|--------|---------|---------|---------|
| C603080005 | --- | 250 | 90 | 0,03 | 4x22 | 13,5 | 23,9 | - | 6,4 | 2,3 | - | 15,7 | 24,1 | 4,3 | 9,1 | 3 | 1,5 | - | 17 | 71,1 | 22,4 | - | - |
| C603080010 | --- | 250 | 90 | 0,03 | 4x22 | 11,4 | 23,9 | 6,6 | 4,1 | 2,3 | 5,8 | 15,7 | 24,1 | 4,3 | 8,1 | 6,4 | 1,5 | 4,6 | 17,8 | 67,3 | 18,8 | 5,6 | 9,4 |
| C603080015 | --- | 900 | 90 | 0,15 | 6x44 | 25,4 | 36,3 | 6,6 | 4,8 | 0,8 | 8,1 | 22,1 | 35,1 | 5,1 | 25,4 | 12,7 | 2,5 | 7,1 | 38,9 | 139,7 | 57,4 | 19,8 | 32 |
| C603080020 | --- | 2200 | 90 | 0,26 | 8x53 | 25,4 | 38,1 | 6,6 | 6,4 | 1 | 17,5 | 22,1 | 35,1 | 7,6 | 33,3 | 12,7 | 3 | 8,4 | 46,7 | 173 | 68,3 | 27,4 | 35,1 |
| C603080025 | --- | 3200 | 90 | 0,66 | 10x79 | 41,4 | 57,2 | 8,4 | 7,9 | - | 25,9 | 41,4 | 57,4 | - | 42,9 | 19,1 | 4,1 | 11,2 | 64,8 | 271,5 | 105,9 | 40,6 | 58,9 |