

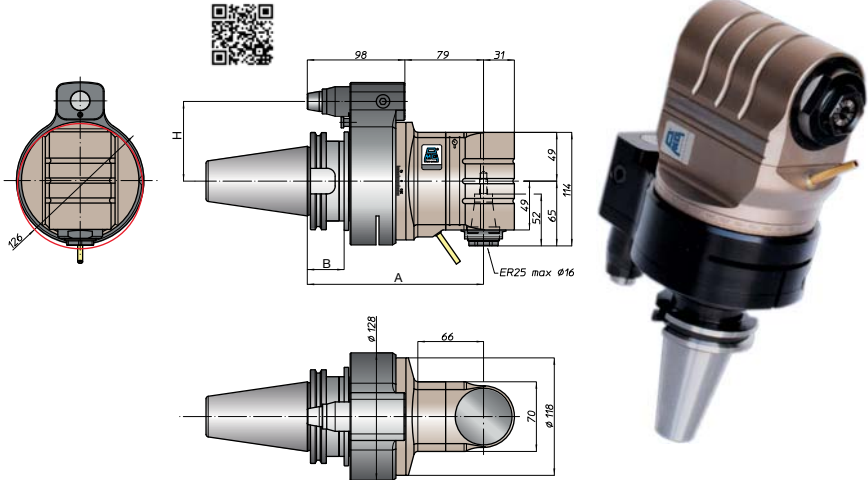

Angular head

Angular head in steel machined from solid, body treated with niploy, anti-corrosion treatment, which guarantees high protection against rust, aggressive lubricants and acids, oblique bearings in the ABEC 7/9 precision class, Gleason gears with rectified involute, maximum performance and less vibrations.



Code	€	Coupling	Max revolutions no. (rev/min)	ER collet	Ratio	Max drilling ø (mm)	Max tapping ø (M)	A (mm)	B (mm)	H (mm)
C99030005	---	40-DIN 69871	5000	25	1÷1	16	12	172	35	65
C990300010	---	50-DIN 69871	5000	25	1÷1	16	12	177	35	80
C990300015	---	MAS BT40	5000	25	1÷1	16	12	172	35	65
C990300020	---	MAS BT50	5000	25	1÷1	16	12	185	45	80
C990300025	---	HSK-A 63	5000	25	1÷1	16	12	181	44	65



Angular head

Angular head in steel machined from solid, body treated with niploy, anti-corrosion treatment, which guarantees high protection against rust, aggressive lubricants and acids, oblique bearings in the ABEC 7/9 precision class, Gleason gears with rectified involute, maximum performance and less vibrations. Internal coolant cooler max 70 Bar.

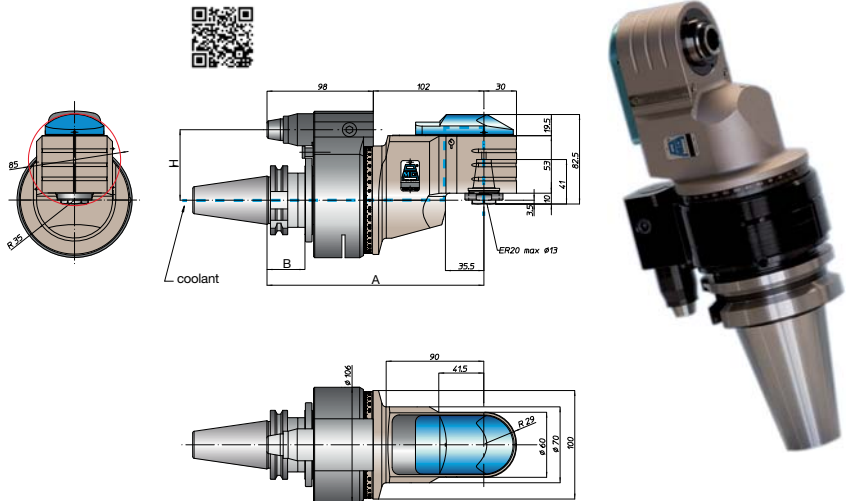

Code	€	Coupling	Max revolutions no. (rev/min)	ER collet	Ratio	Max drilling ø (mm)	Max tapping ø (M)	A (mm)	B (mm)	H (mm)
C990350005	---	40-DIN 69871	4500	20	1÷1	13	10	200	35	65
C990350010	---	50-DIN 69871	4500	20	1÷1	13	10	200	35	80
C990350015	---	MAS BT40	4500	20	1÷1	13	10	200	35	65
C990350020	---	MAS BT50	4500	20	1÷1	13	10	208	45	80
C990350025	---	HSK-A 63	4500	20	1÷1	13	10	209	44	65