

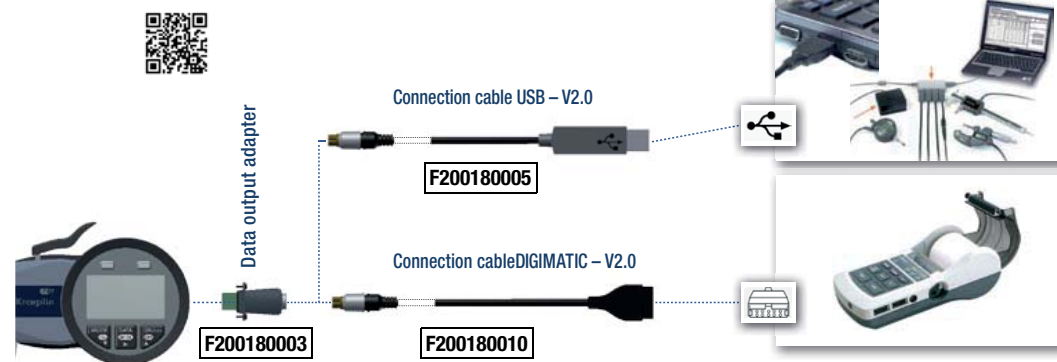

### Data output interface

Interface for data output from the digital arm comparator to printing or data processing systems. **When ordering always specify the serial number of the interface and/or accessories.**



Code	€	Instrument series	Data exit	Length (m)
F200180003	---	C/G	-	-
F200180005	---	-	USB	2

Code	€	Instrument series	Data exit	Length (m)
F200180010	---	-	Digimatic	2

COMPARATORS  
BORE GAUGES



### Set of bore gauge tracers

Set of bore gauge tracers for comparative measurement of internal diameters. Can be used both for individual controls and series controls, in the metrology laboratory or on the machine.

As well as measuring the diameter it is possible to check for any geometrical errors in the bore, such as roundness, cone and barrel shape. The instrument is repeatable to a thousandth (0.001 mm). Operating principle: the two halves of the tracer, tightening together inside the bore, transmit movement to the measuring pin, in a ratio of 1:1. The measuring pin in turn transmits the movement to the comparator. The bore gauges can be used with all comparators with a  $\varnothing 8$  h7 stem, with a minimum length of the stem 20mm. The set does not include the comparator holder, length 51 mm, and the measuring pin. Measuring pins for the sets with tracers with hard metal contacts are made of hard metal.

**Comparator and zeroing rings are not included in the set, but are essential for zeroing.**

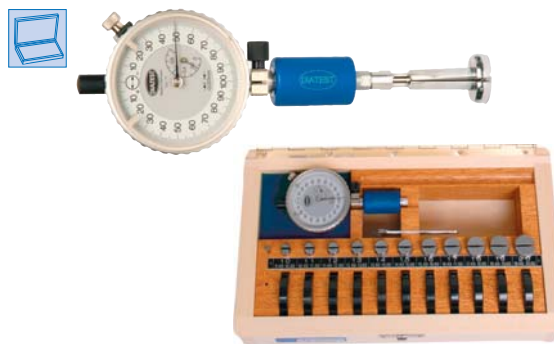

Code	€	Measurement field (mm)	Maximum measuring depth (mm)	No. of measuring heads	Contact points
F250250005	---	1,5÷3,95	17 up to $\varnothing 2,45$ / 22 from $\varnothing 2,3$	9	hard metal
F250250010	---	3,7÷9,8	40 up to $\varnothing 8,3$ / 50 from $\varnothing 8,2$	12	hard metal
F250250015	---	9,4÷20,6	50	11	hard metal
F250250020	---	20,4÷30,6	90	10	hard metal
F250250025	---	0,95÷1,55	11	5	chrome steel
F250250030	---	1,5÷3,95	17 up to $\varnothing 2,45$ / 22 from $\varnothing 2,3$	9	chrome steel
F250250035	---	3,7÷9,8	40 up to $\varnothing 8,3$ / 50 from $\varnothing 8,2$	12	chrome steel
F250250040	---	9,4÷20,6	50	11	chrome steel
F250250045	---	20,4÷30,6	90	10	chrome steel



### Quick-opening stand with adjustable base

Quick-opening stand with adjustable lever lifting system and locking screw. Connection with locking prism, height adjustable column with screw for fine adjustment. Particularly indicated for use with bore gauge tracers item F25070 and F25025.

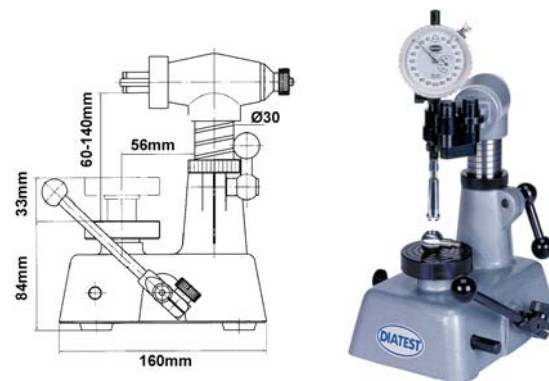

Code	€	$\varnothing$ base (mm)	Maximum base height (mm)	Height adjustment (mm)	Column $\varnothing$ (mm)	Lunghezza colonna (mm)
F250400005	---	58,75	33	60÷140	30	80