



Vice for 5-axis machining centers

Vice for 5-axis working centers, raised part gripping, with SinterGrip system for gripping parts of only 3.5 mm, self-centering closure nut, hardened and ground steel body, jaws with simple and double step, possibility to lock parts on different planes. Supply with: 10 SinterGrip STD inserts for steel, wrench, side locking kit.



0015

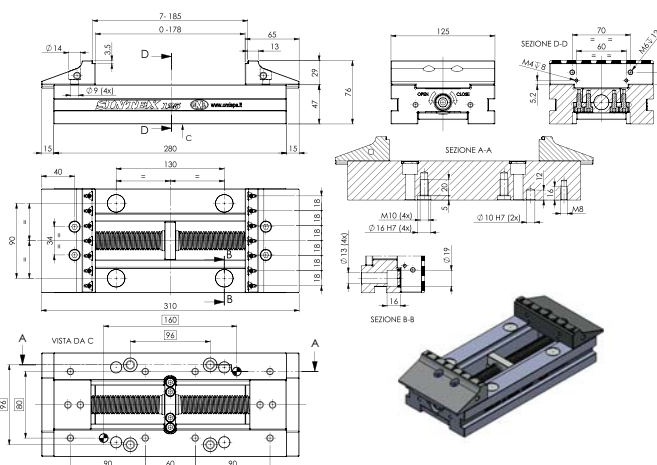

0020

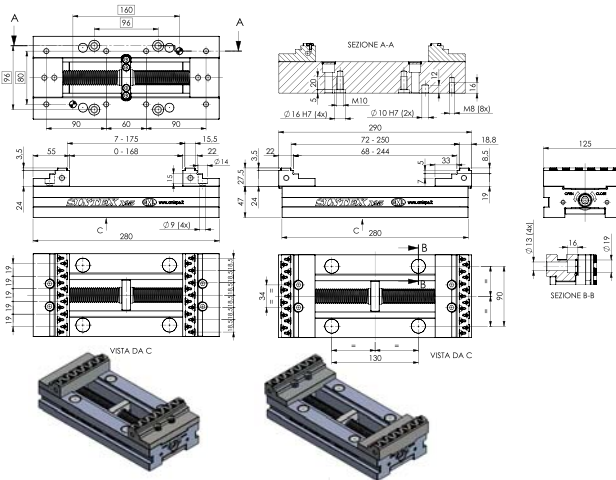

Interface Plate

C55388

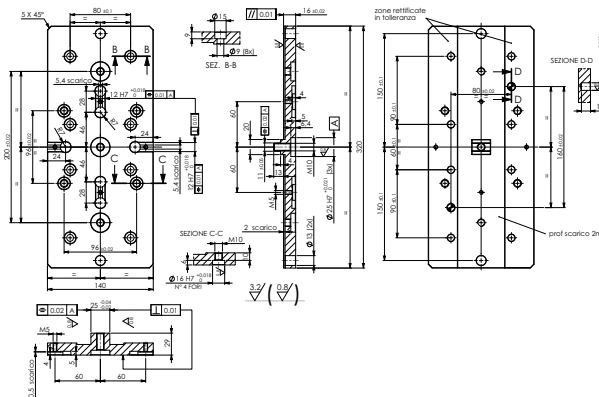

0015 - Supply: 10 SinterGrip STD inserts for steel, wrench, side stop kit.

0020 - Supply: 10 SinterGrip STD inserts for steel, 10 protection inserts, key, side stop kit.

C55386	€	Min / max opening (mm)	Jaws width (mm)	Repeatability of locking (mm)	Precision tolerance of the base (mm)
C553860015	---	7/185	125	± 0,01	± 0,01
C553860020	---	7/250	125	± 0,01	± 0,01

C55388	€	Interface plate
--------	---	-----------------

C553880010 --- Interface plate complete with 1 pair of keys and 1 pair of brackets for cod. C553860005-0020.